



F150 First Floor, Cherwell Business Village, Southam Road, Banbury OX16 2SP
t +44(0)20 7235 7938 f +44(0)20 7235 0074 e hqsec@pipeguild.com www.pipeguild.com

2023 TECHNICAL AWARDS ENTRY FORM

Entry Deadline: Thursday 30th March 2023

Please tick which categories you are entering (entries may be submitted in multiple categories using the same entry form)

- | | |
|-------------------------------------|-------------------------------------|
| Landbased Pipeline Project Award | <input type="checkbox"/> |
| Landbased Pipeline Technology Award | <input type="checkbox"/> |
| Utility Pipeline Project Award | <input type="checkbox"/> |
| Utility Pipeline Technology Award | <input checked="" type="checkbox"/> |
| Subsea Pipeline Project Award | <input type="checkbox"/> |
| Subsea Pipeline Technology Award | <input type="checkbox"/> |
| iICE Award | <input type="checkbox"/> |

1. **Brief title of entry:** Large Diameter PE Cutter
2. **Company name:** Steve Vick International Ltd
3. **Signed:** 
4. **Date:** 27 March 2023
5. **Company contact name:** Jules Daniell
6. **Telephone:** 07531 962 055
7. **Email:** Julia.daniell@stevevick.com

8. **Precis of your entry (50 words):**

Cutting large diameter PE accurately is difficult and existing technology comes with health and safety concerns. Steve Vick International (SVI) have addressed these concerns and developed, as a joint NIA funded project with Northern Gas Networks (NGN), their latest innovation for larger diameter PE, the PE Pipe Cutter.



F150 First Floor, Cherwell Business Village, Southam Road, Banbury OX16 2SP
t +44(0)20 7235 7938 f +44(0)20 7235 0074 e hqsec@pipeguild.com www.pipeguild.com

9. Summary of entry:

Innovation delivering Improved Safety

SVI were approached by Northern Gas Networks in late 2020 with the challenge of finding a new method for cutting large diameter PE Pipe that is safe, accurate and cost effective. SVI set themselves an additional goal to make a low-profile machine that would reduce excavation size and ease of setup in all conditions.

SVI developed the design over 18 months, using their mill and lathe to rapidly prototype components as their ideas evolved. This allowed them to move through concepts quickly without external supplier delays. As part of this work, they created a custom pneumatic control system to meet the required safety standards.

This led to their final design. Rather than a circular disc, this machine uses a custom milling tool attached to a 1 horsepower pneumatic motor. To perform a cut, you first plunge the motor into the pipe where it automatically locks in place. You can then begin cutting by pushing the machine around by hand. When the cut is complete, you simply turn the lever on the front and the unit releases from the material.

The PE Pipe Cutter is safe to use in above ground and in ground scenarios and requires minimal clearance. With a total working height of 170mm the PE Pipe Cutter is ideal for use where space is restricted.

With safety being paramount in the design process, the cutting element remains enclosed in the wall of the pipe throughout the circumferential cut. It is this unique safety feature that sets the PE Cutter aside from traditional tooling, such as rotary cutting disc machines and chainsaws, which have been long associated as hazardous, with potential to cause serious injury.

Handsaws are safe but they can be extremely laborious, and time consuming, and other hand-held cutting devices have become non preferred due to the risks associated with using them in a trench environment.

The PE Pipe Cutter has provided the pipeline industry with a safer, quicker, and more accurate method for cutting large diameter PE which wasn't previously available. With Innovative cutting technology resulting in no exposed blades, it sets this tool apart from any other method in terms of safety and accuracy.

Patent pending.

Check out the PE Cutter Pipe Cutter in action https://youtu.be/SH6_Zoe1HT8

Future Development

The Iron Mains Replacement Programme (IMRP), which has become known as the 30/30 programme requires the Gas Distribution Networks (GDN's) to replace all 'at risk' iron mains (i.e. those within 30 metres of a property) within 30 years of 2002. Although we are two thirds of the way into this programme, we still have an additional 10 years left until this programme is due to end. The PE Pipe Cutter could be an instrumental tool in



F150 First Floor, Cherwell Business Village, Southam Road, Banbury OX16 2SP
t +44(0)20 7235 7938 f +44(0)20 7235 0074 e hqsec@pipeguild.com www.pipeguild.com

the Gas Mains Replacement Programme to ensure the safety of operatives and to reduce the environmental impact of the works involved.

Not only are the GDN's working to replace all old metallic mains but they are focusing their efforts towards a greener future. By upgrading to plastic (PE) ensures a long-term safe network and means everything is on track to replace fossil gas with hydrogen. This switch is essential for meeting energy demands in ways that protect the planet. The PE Pipe Cutter is future proof and aligns with the strategy for a greener future. PE Pipe is the future of energy distribution, and the PE Pipe Cutter brings a safer and more efficient method of cutting this material, especially with larger diameters.

SVI are currently working on a development to enable the PE Pipe Cutter to cut PE pipe with a wall thickness of 100mm or more. In addition, they are also developing an electronically powered cutter for water and export markets which removes the requirement for a compressor unit.

Cost Reduction

The unique, low-profile machine is pneumatically powered and capable of accurately completing a full circumferential cut on 630mm PE pipe in less than 5 minutes. This compares favorably to standard cutting techniques and represents a significant time and cost saving in terms of manpower whilst also improving the safety of the operator. Over the products' lifecycle, these time and safety improvements will add up to a significant efficiency benefit for the customer.

Northern Gas Networks performed a cost savings analysis for the PE Pipe Cutter which identified a total cost saving of £15.40 per cut on 250mm and 355mm diameter PE pipe and a total cost saving of £16.33 per cut on 400mm and 630mm diameter PE pipe.

Sustainable Design

In the design of the product, safety and accuracy were key factors as well as the environmental aspects. Designed with an extra environmental feature, the exhausted air from the motor is used to generate a vacuum, that draws 98% of the swarf away from the cutting area into a bag located in the storage tin. This reduces the amount of microplastics introduced to the environment which is extremely important for the water networks.

New Opportunities

Replacement projects that were previously unfavorable due to the time constraints and manpower requirements are now achievable. The PE Pipe Cutter can now assist the networks in completing the 30/30 program to schedule by allowing them to complete works which have previously been more challenging to replace.



F150 First Floor, Cherwell Business Village, Southam Road, Banbury OX16 2SP
t +44(0)20 7235 7938 f +44(0)20 7235 0074 e hqsec@pipeguild.com www.pipeguild.com

Eight initial units were made as part of the development process, and are now being trialed and tested in Switzerland, Denmark, and the USA as well as across the UK. Feedback from these tests has fed into their production model, that is now available for purchase and hire. This development has allowed this product to make a positive impact across not just gas but also water and the broader utilities sector.

Development Project Challenges

Through the development process SVI came across numerous challenges to ensure the product met the safety, accuracy, and environmental objectives.

Vibration – this was a massive challenge for SVI due to the aggressive nature of the cut and the power of the motor. Experimentation with different motors at different RPM and torque helped identify the final motor choice. Bespoke cutting tool design to alter the aggression of the cutting surface also helped overcome this challenge.

Achieving a round cut – it was essential that the machine delivered a perfectly round cut. To get around this issue the machine is mounted on a tailor-made chain designed specifically to maintain a grip on a smooth surface. The position of the motor has been carefully designed and tested to ensure even weight distribution when cutting.

Unfamiliar Technologies - During the project design phase to create a pipe cutting machine, the development team encountered unfamiliar technology. However, SVI dealt with this challenge in a proactive and innovative way. First, our team took the time to research and study the new technology, gaining a thorough understanding of its capabilities and limitations. Next, the team engaged in experimentation and prototyping, using trial and error to identify the most effective approaches for integrating the unfamiliar technology into the machine design. Throughout the process, our team remained open-minded and willing to adapt, using their collective creativity and problem-solving skills to overcome any obstacles that arose. Ultimately, the team successfully incorporated the new technology into the design, resulting in a cutting-edge and efficient pipe cutting machine.

Market Adoption - introducing a different method of cutting to the market was initially a challenge. Persuading operatives to trial a new technique and method over well used and ingrained existing tooling was an obstacle that required perseverance. This was overcome by demonstrating the cutter and its key benefits; improved accuracy, efficiency, and cost savings to both the operator and the GDN.

Success to date

SVI have a patent pending on this design due to its collection method. This successful innovation has now been approved within NGN and will soon to be adopted by the other GDNs. Considering the tier two and tier 3 replacement program in the remainder of GD2, and looking towards GD3, the GDN's have welcomed the timing of this product coming to market.



F150 First Floor, Cherwell Business Village, Southam Road, Banbury OX16 2SP
t +44(0)20 7235 7938 f +44(0)20 7235 0074 e hqsec@pipeguild.com www.pipeguild.com

Michael Charlton, Innovation Implementation Manager at Northern Gas Networks commented on the performance of the PE Pipe Cutter, *“Once the cutting started, I was impressed with the way the kit “vacuumed” up the shavings, which is an environmental issue, but also leads to a substantial amount of customer complaints each year as they fly and blow around sites. The cuts themselves ranging from between two and a half minutes (250mm) to just under five minutes (630mm) which is far quicker than with a hand tool, as it is challenging to cut through the entire pipe evenly and there is often a need to rework the cut to make neat ahead of joining.”*

Ancillary Entry Information

(Entry restricted to normal type face and font size on this form plus no more than 3 pages of A4 drawings or photographs)

SEE ANCILLARY ENTY INFORMATION ON THE NEXT THREE PAGES

PE PIPE CUTTER PHOTOS



A thick 800mm pipe that the PE Pipe Cutter cut in just over 5 minutes



The PE Pipe Cutter on field trial at a site in Chelmsford. This pipe was 400mm and cut in just over two minutes.

PE PIPE CUTTER

TECHNICAL DRAWINGS

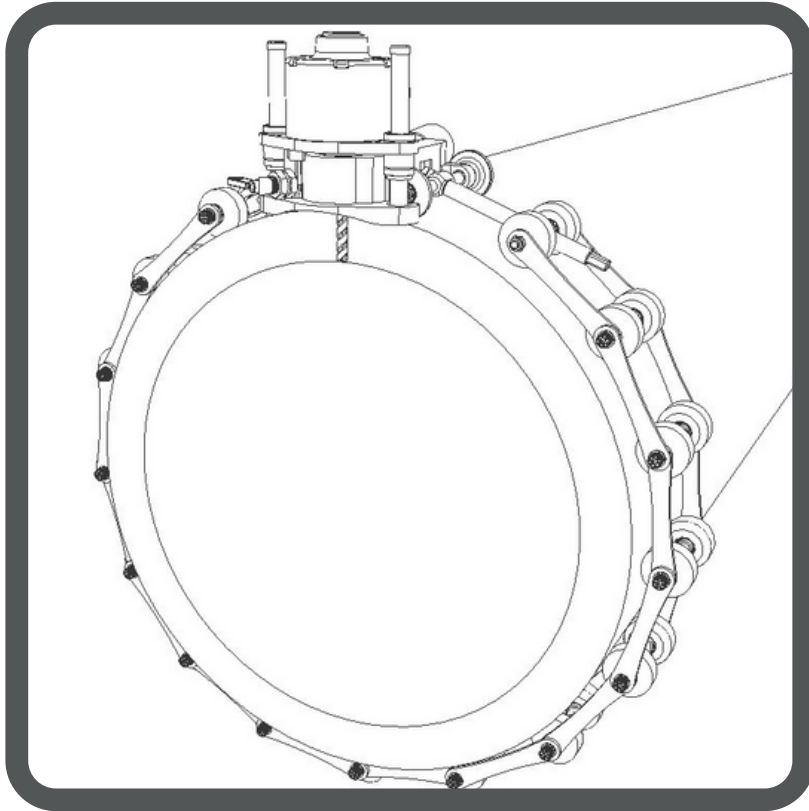

The machine on PE pipe with the cutter engaged.

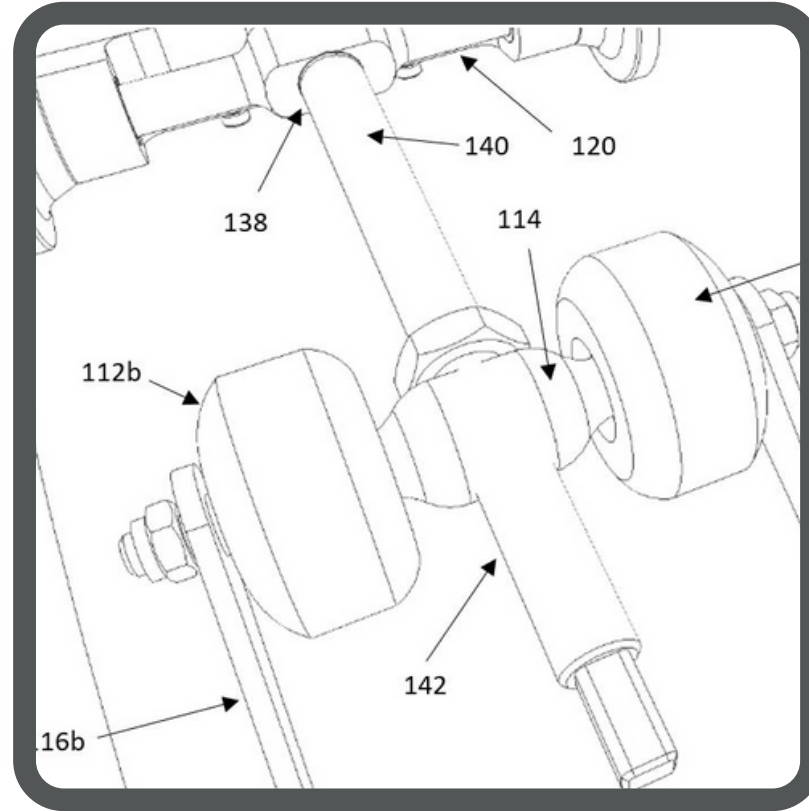

The chain adjustment method which allows the operator to cut any diameter of PE pipe.

PE PIPE CUTTER

TECHNICAL DRAWINGS

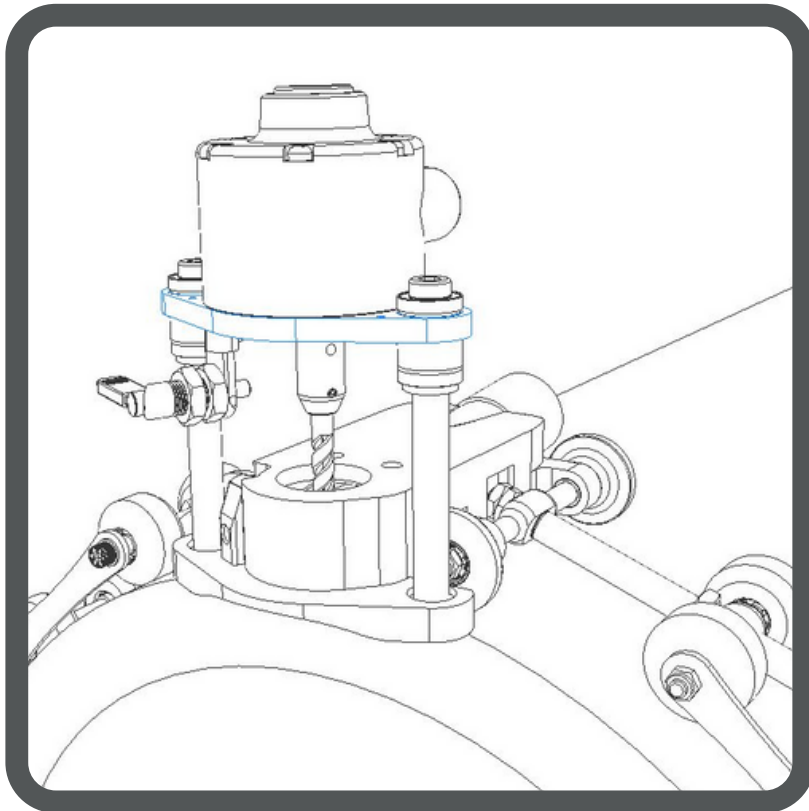

The PE Pipe Cutter has a low profile design which enables a smaller excavation size compared to other techniques.

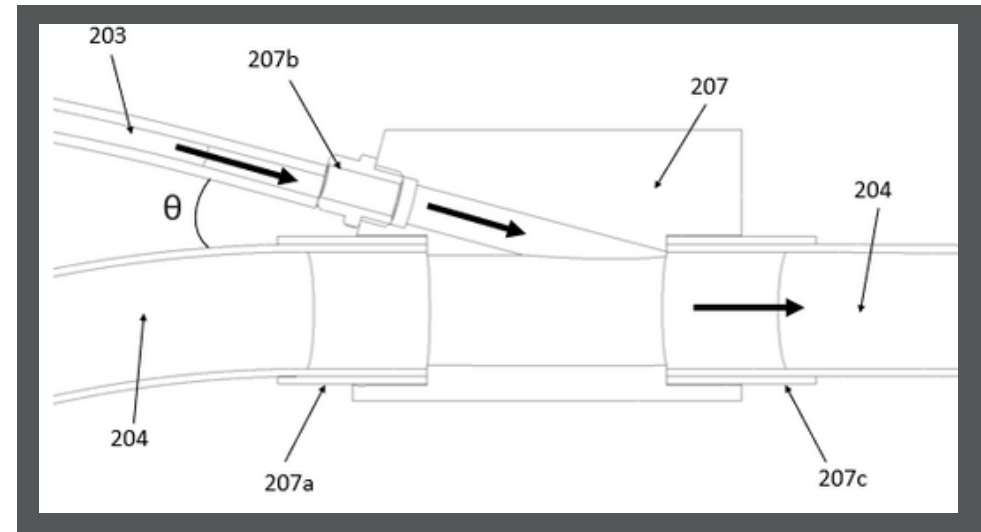

This shows how the internal suction system operates to draw 98% of the swarf away from the cutting area into a bag, reducing the amount of microplastics introduced into the environment.